

# CELESTE

5311

TRADITIONAL 2-HOLE KITCHEN  
MIXER TAP

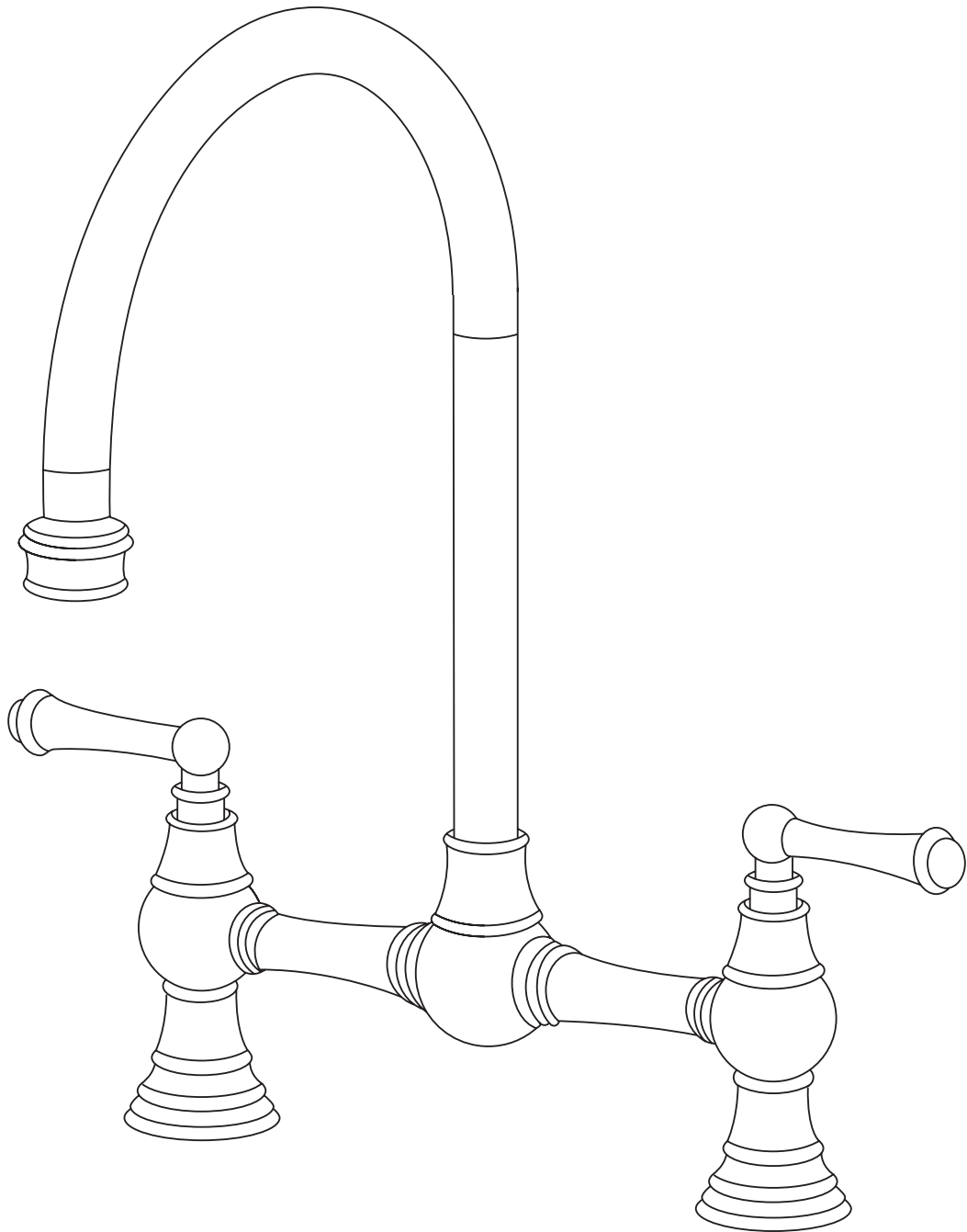

EN  
INSTALLATION  
AND CARE GUIDE

Please retain for future reference

# LUSO

# INTRODUCTION

Thank you for purchasing the Celeste Traditional 2-Hole Kitchen Mixer Tap.

Please read this guide carefully before installing, using and cleaning this product, and retain it for future reference. Please also note that this mixer tap has been fully tested before being dispatched, which may mean there is water residue on some of the parts.

If you have any queries in relation to this product or guide, please contact our Customer Service team on 020 3370 4057.

## PRODUCT KIT

- A** Tap Body
- B** O Rings (x2)
- C** Washers (x2)
- D** Retaining Nuts (x2)
- E** Flexible Hoses (x2)

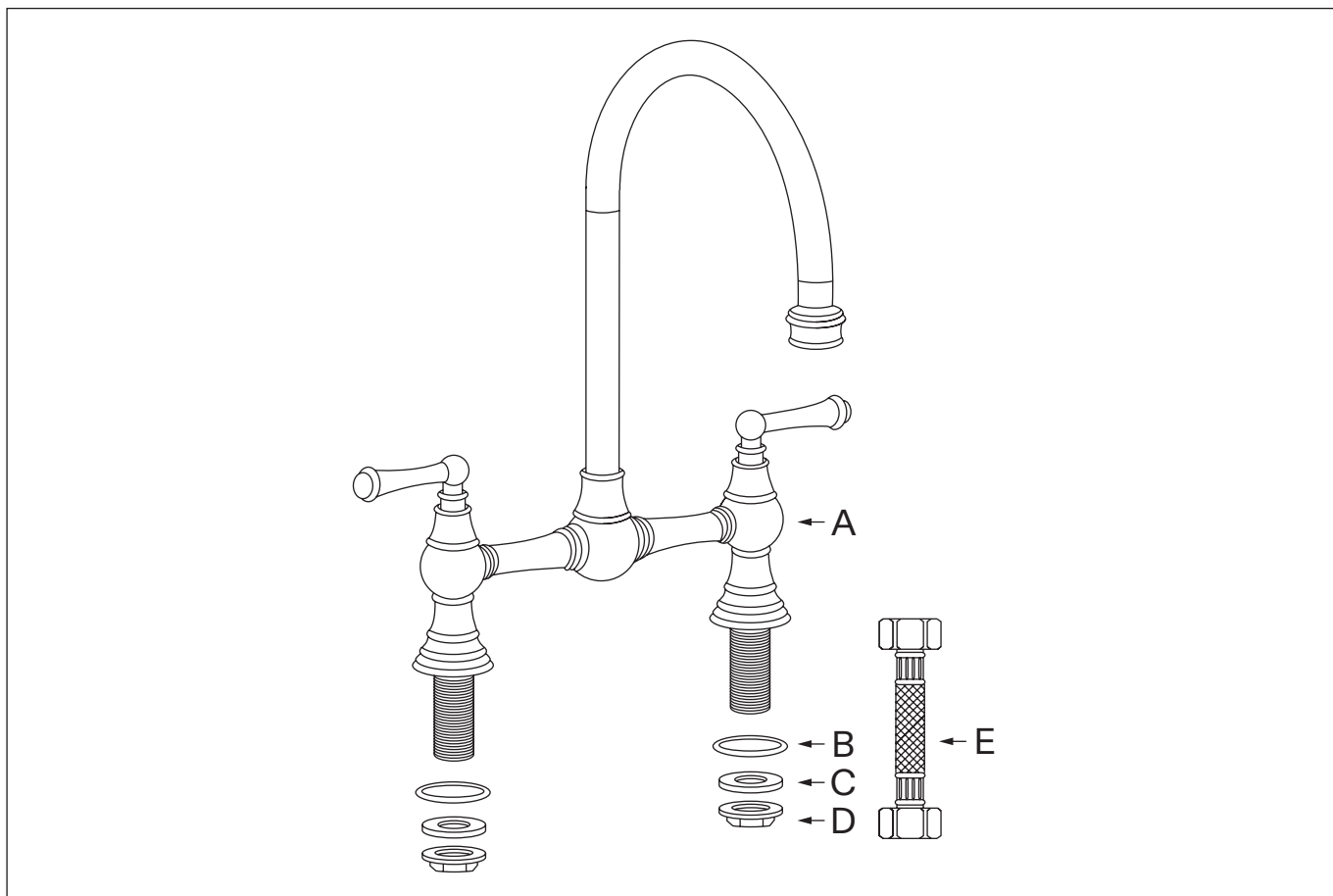

# INSTALLATION STEPS

Before installation, please note that this tap is designed for deck mounting only, and we recommend that it is installed by a fully qualified plumber.

It is suitable for use on all boiler systems including pumped, gravity and combination boilers to a maximum pressure of 5 bar - pressure above this may require the fitting of reducer valves.

Please also note that failure to flush your plumbing system as part of the installation process will void the product guarantee. In addition, you must fully test the product before tiling and/or plastering, etc as Lusso will not be held responsible for any costs involved in the removal of the tap if you find there is a fault.

- 1 Carefully check the dimension drawing and mark the position for the tap. Next, remove the nuts and washers from the fixing section.
- 2 Fix the tap onto the kitchen surface with the washers and retaining nuts.
- 3 Connect the hot and cold water hoses by hand, and test the tap.

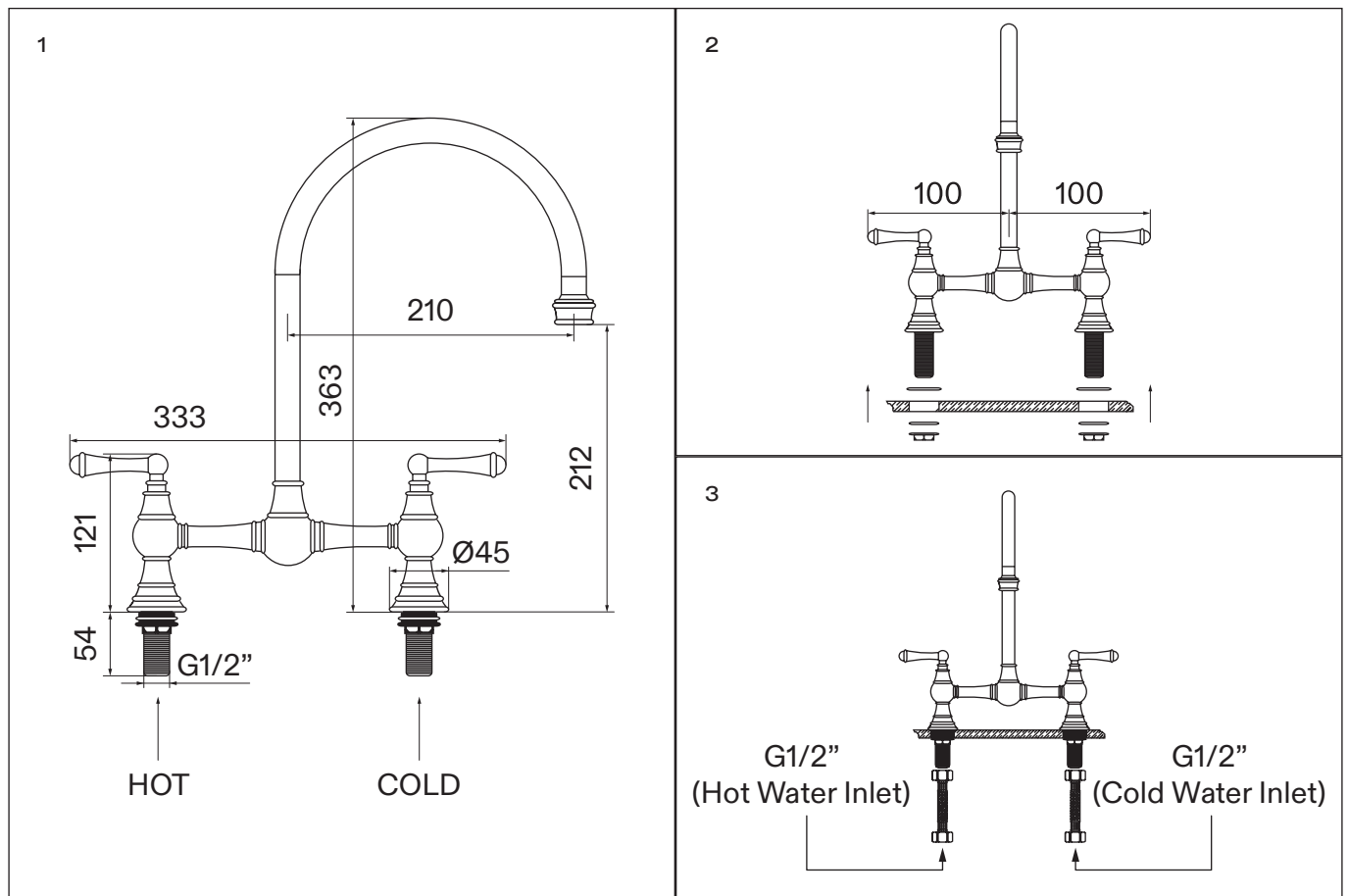

# CARE INSTRUCTIONS

To clean and maintain the flawless finish of this product, please follow the below instructions. Improper maintenance will void your product guarantee.

✓ Clean with a damp cloth.

✗ Do not use acidic cleansers.

✗ Do not use abrasive cleansers or cloths.

Go to [Lusso.com](https://Lusso.com) to activate your guarantee.

# TROUBLESHOOTING

## **Why is the tap producing hot water when cold is selected, and vice versa?**

It's likely that the hot and cold pipes have not been connected the right way around - please check and amend.

## **There is a leak from the top of the tap - what should I do?**

In this instance, the cartridge may have become loose during installation. To tighten it, firstly remove the lever from the tap by unscrewing the hex screw with the provided allen key. Next, put the screw to one side, then unscrew and remove the dome part of the tap by hand. Finally, tighten the cartridge fixing nut with an adjustable spanner to create a seal and stop the leak, then reassemble the tap.

## **What could cause a fluctuating flow rate or low/no flow from the valve?**

This may be due to either a blockage in the system, incorrect operating conditions, or a clog in the aerator. To unclog the aerator, simply unscrew it, rinse it with water, and reinstall it - if the problem persists, please consult with a qualified plumber.

## **How do I replace the cartridge?**

Firstly, isolate the water to the tap. Next, remove the lever from the tap by unscrewing the hex screw with the provided allen key, put the screw to one side, then unscrew and remove the dome part of the tap by hand. Finally, unscrew the cartridge fixing nut with an adjustable spanner, lift out the cartridge and replace it with a new one - ensuring that the holes are aligned - before reassembling the tap.

# LUSSO

Customer Care: 020 3370 4057

International: +44 20 3370 4057