

# VENDO

G1130

## SENSOR TAP

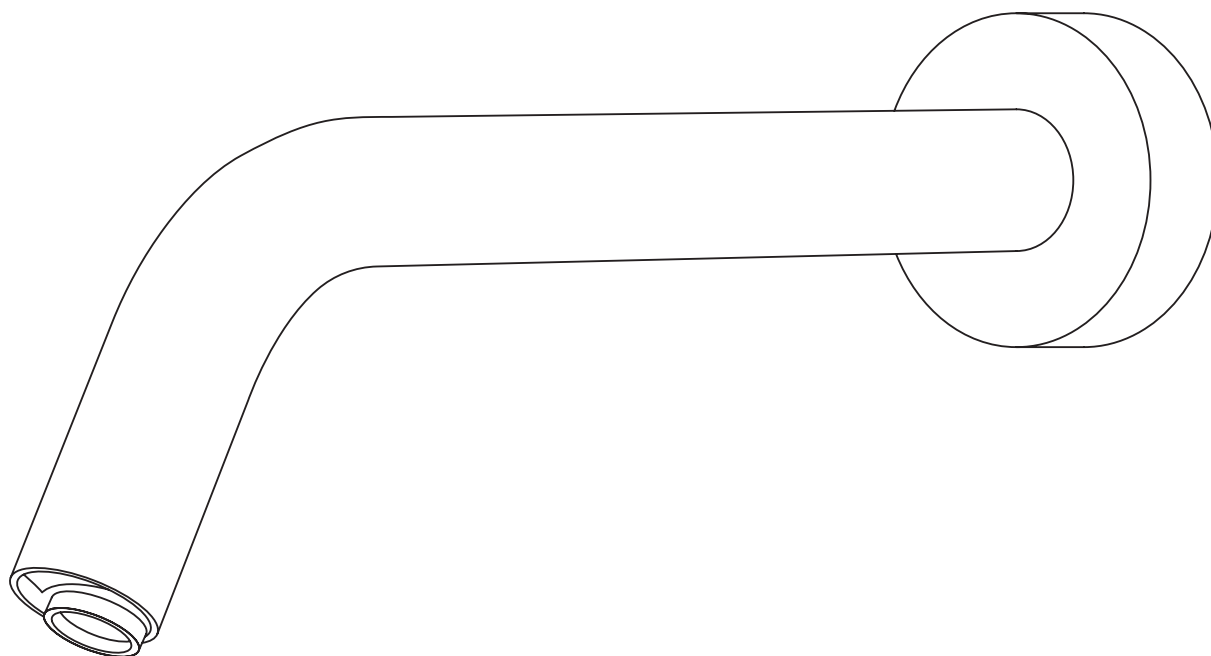

EN  
INSTALLATION  
AND CARE GUIDE

Please retain for future reference

# LUSO

# INTRODUCTION

Thank you for purchasing the Vendo Sensor Tap.

Please read this guide carefully before installing, using and cleaning this product, and retain it for future reference.

If you have any queries in relation to this product or guide, please contact our Customer Service team on 020 3370 4057.

# SPECIFICATIONS

<b>Power Supply</b>	AC: 220~240V / DC: 4*1.5V AA Alkaline Batteries
<b>Sensor Detector Range</b>	5~250mm
<b>Ambient Temperature</b>	1~55°C
<b>Humidity</b>	Max. 90 RH
<b>Water Pressure</b>	0.05~0.7 MPa
<b>Product Consumption</b>	Standby: ≤2W; Active: ≥5W
<b>Flow Rate</b>	2L/min

Sensor cable length: 102cm

Braided hose length: 80cm

Plug cable length: 170cm

# PRODUCT KIT

- A Spout (with hose and cable installed)
- B Screws (x2)
- C Wall Plugs (x2)
- D Control Box
- E Plug

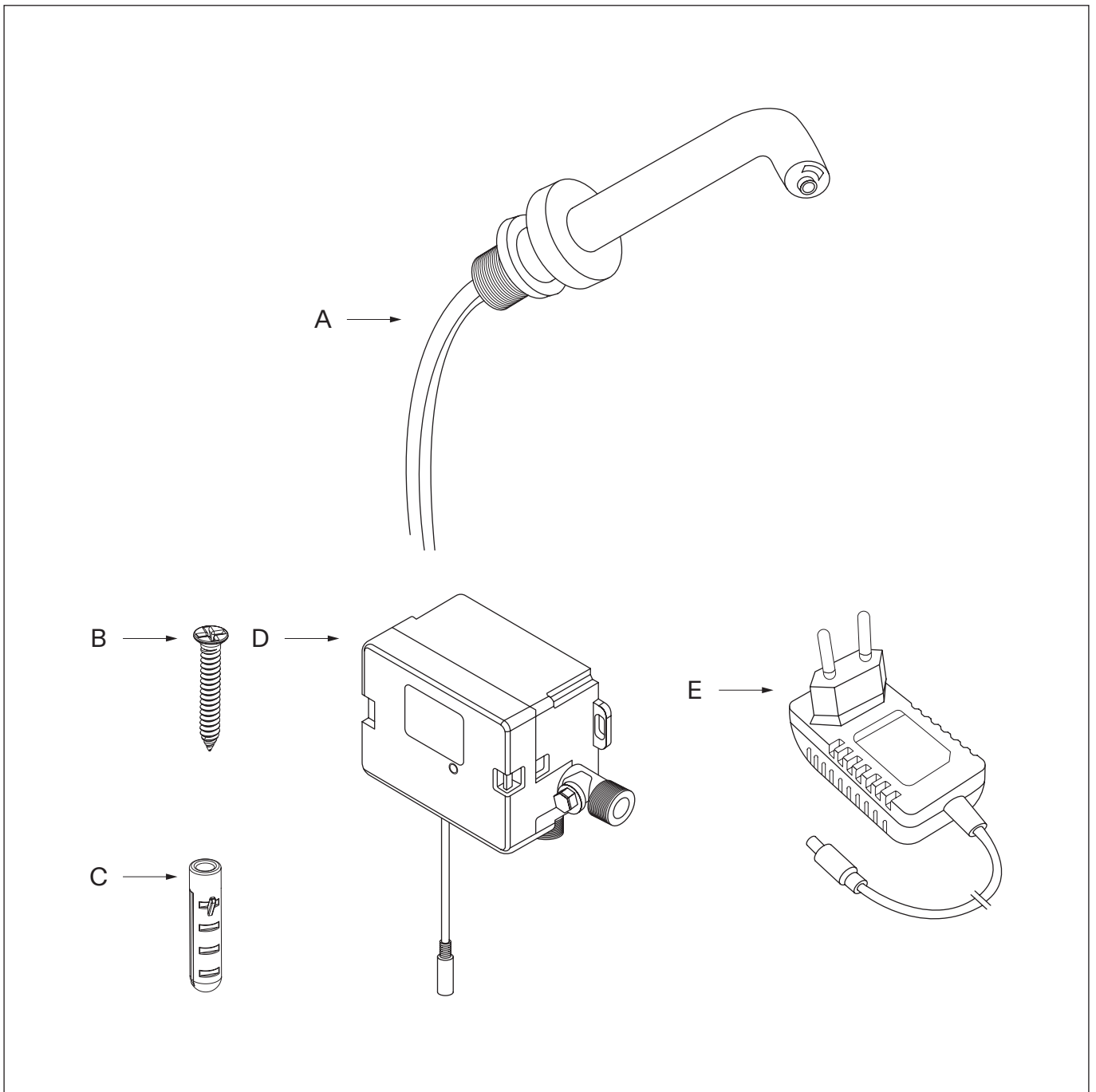

# INSTALLATION STEPS

**Before installation, please note that this tap is suitable for tap water or potable water, and is designed for deck mounting only.**

**We recommend that it is installed by a fully qualified plumber, and that you ensure there is enough space to install the whole system.**

**Please also note that failure to flush your plumbing system as part of the installation process will void the product guarantee. In addition, you must fully test the product before tiling and/or plastering, etc as Lusso will not be held responsible for any costs involved in the removal of the tap if you find there is a fault.**

- 1** Prepare a 32mm diameter PVC tube (used for installation of flexible hose and cable) into the wall. Make a recess in the wall and embed the PVC tube, making sure that each end is flush with the wall.
- 2** Mark installation holes for the tap according to diagram 2 or via the wall mounting plate on the tap. Drill the required holes and fix in the bolts.
- 3** Put the flexible hose and cable into the embedded PVC tube, then fix the spout into position using the provided screw as shown in diagram.
- 4** Position the control box on the proposed wall and install with the provided screws.
- 5** Connect the water inlet and outlet supply to the control box and fasten with a wrench. Next, connect the cables in the correct directions.
- 6** Test the tap and check for leaks, and ensure that the plug and control box are installed where they will not come into contact with water.

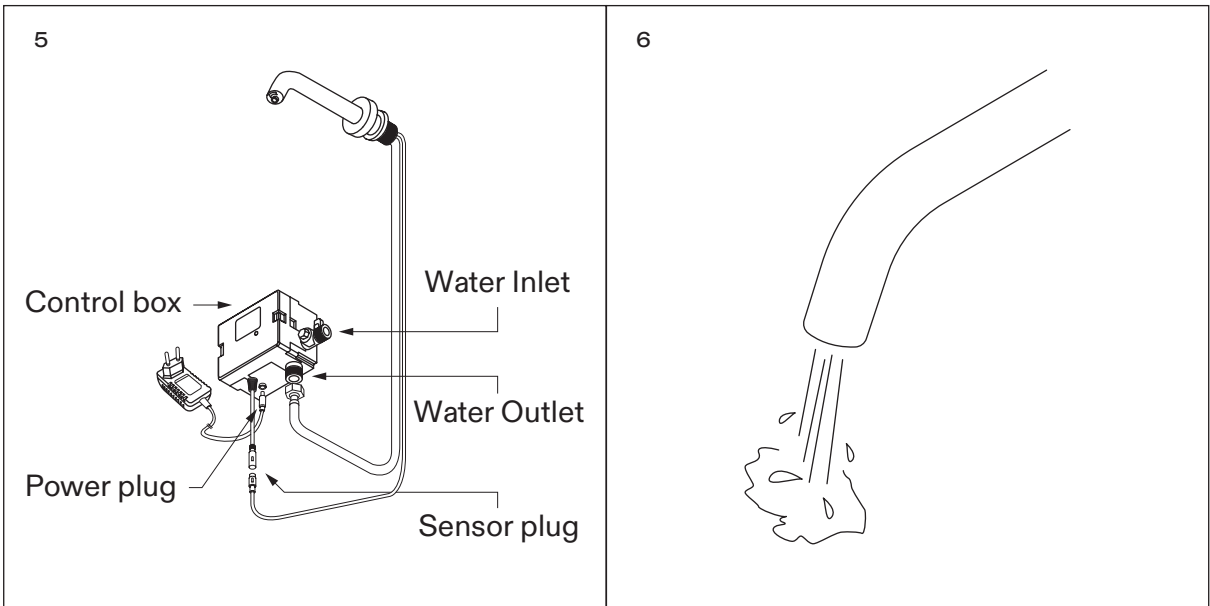
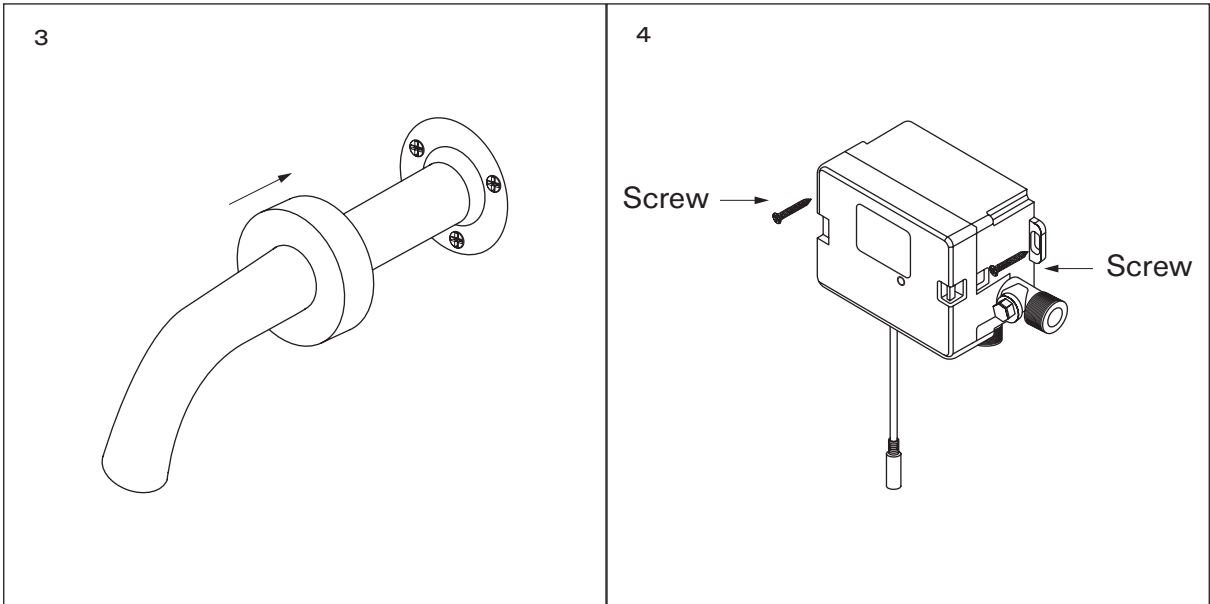
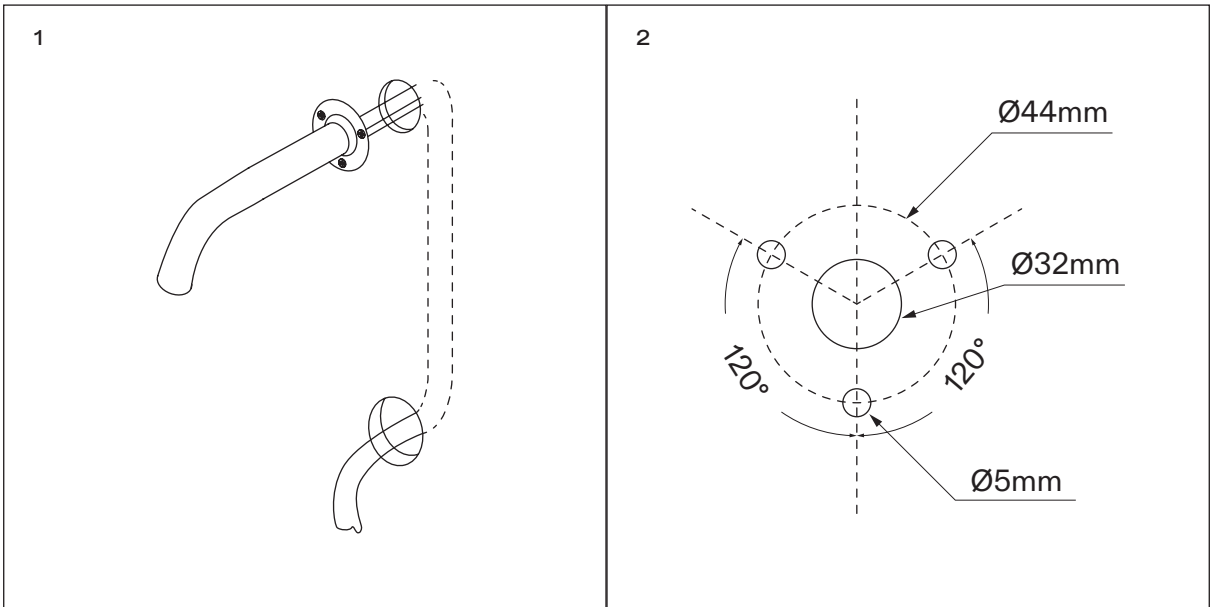

# TESTING THE SENSOR TAP

Once you have connected the power, the sensor light will stop flashing after 10 minutes. Please make sure there are no objects in front of the sensor.

If the inner light is still flashing, please adjust the spout direction slightly until the flashing stops. If the previous step has failed to stop the light flashing, please disconnect the sensor cable and repeat the step again.

# USING THE SENSOR TAP

Place your hands under the spout (approximately 50-120mm from the sensor) and the water will dispense. Do not block the sensor with your hands.

To stop the water flow, move your hands away from the sensor and the water will stop. Please note, the tap is programmed to run in 30-second cycles. This means the water will automatically cut off after 30 seconds, regardless of whether your hands are still under the sensor. This cycle duration cannot be changed or interrupted early.

# INSTALLING/REPLACING A BATTERY

- 1 Open the control box and take out the battery case.
- 2 Open the cell case and install four AA cell batteries.
- 3 Put the battery case back into place.

# CLEANING THE FILTRATION SYSTEM

The control box is equipped with an independent filtration system, however, due to poor water quality inside the pipe system or long-term usage, a blockage in the filter system may occur. To resolve this by cleaning the filtration system, please follow these steps:

- 1 Turn off the angle valve to stop the water from flowing during cleaning.
- 2 Unscrew the brass cover located on the water inlet connection, take out the filter and rinse it with clean water.
- 3 Fix the filter back into position and carefully check for leaks.

# TROUBLESHOOTING

## **There is no water flow and the sensor isn't flashing - what should I do?**

Wipe the sensor window clean, and check the power supply and the connections of each joint. If you're using batteries, make sure the batteries are correctly installed and replace with new batteries if they have been in use for some time.

## **There is low or no water flow while the sensor is flashing - what should I do?**

Please allow 10 minutes for the tap to full operate following installation. Also make sure that the water valve is opened completely, however if the problem persists, turn off the water valve, disassemble the spout and clean the aerator and/or filtration system.

# SAFETY WARNING

Please **DO NOT** disassemble, repair or refit the products as this could lead to an electric shock or product breakdown.

# CARE INSTRUCTIONS

To clean and maintain the flawless finish of this product, please follow the below instructions. Improper maintenance will void your product guarantee.

✓ Rinse the surface of the product with clean water.

✓ Dry with a soft cloth.

✗ Do not use acidic cleansers.

✗ Do not use abrasive cleansers or cloths.

Go to [Lusso.com](https://Lusso.com) to activate your guarantee.

# LUSO

Customer Care: 020 3370 4057

International: +44 20 3370 4057